

SB56

Manual ham derinder

The enhanced sanitation, the reduced maintenance costs and the optimized ergonomics make the SB 56 an outstanding piece of equipment. Designed for intensive industrial use, the model SB 56 is conceived to process continuously at high speed with the best possible yield.



When reliability becomes important

Cretel designs and manufacture high quality machines and equipment with focus on hygiene, durability and efficiency, by delivering goods with the best cost benefit.

Cretel owes its privileged market position to its ability to develop a standard range of products and tailor-made solutions.

Thickness control

Equipped with a thickness wheel control adjustment is possible to derind the skin with a layer of fat (when adjusted on the maximum gap)

Applications

To remove the tissue that surrounds most of meat cut without loss of valuable meat (membrane skinning) and to derind skin and/or fat of rounded meat cuts, such as veal, beef and pork.

Technical Features

TECHNICAL FEATURES		
MODEL	DESCRIPTION	PROD. SPEED
SB56	Automatic membrane skinner & derinder, equipped with a 72T toothed roller	24 m / min

Options

OPTIONS		
POS	DESCRIPTION	MODEL
EW001	Electrical wiring 3 x 230V – 50/60 Hz	SB56
EW004	Chainwheels for 60Hz	
TR001	92T toothed roller instead of 72T (standard)	



Layout

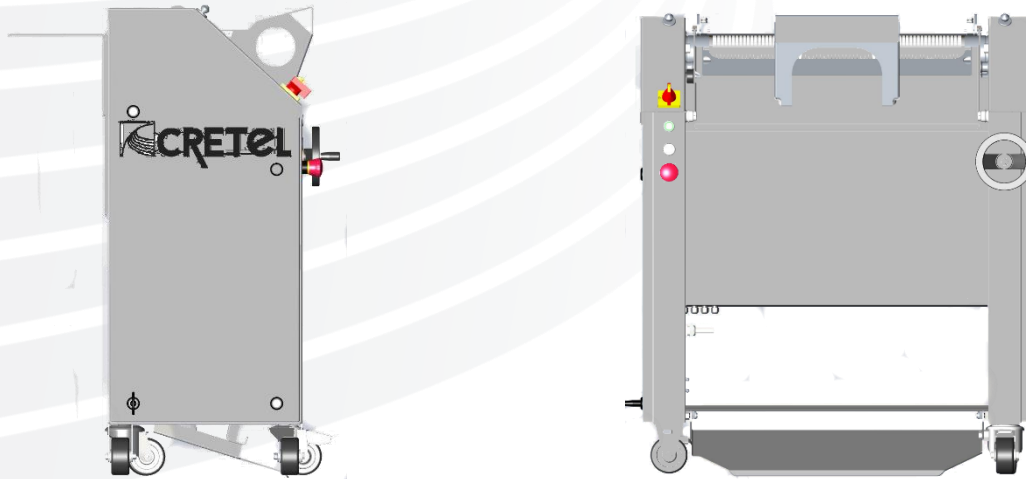

Layout

Skinning width	Weight	Motor	Dimension (L x W x H)
560 mm	167 kg	0.75 kW	855 x 531 x 990 mm

