

# 362 Fish versions



## The tabletop fish skinner

Compact bench tabletop fish skinner, designed for efficient and fast skinning of a wide range of fishes. The unique blade or blunt system technology is based on 35 years' experience and appreciated for their easy of use, reliability and long life span.



### When reliability becomes important

CreTEL designs and manufacture high quality machines and equipment with focus on hygiene, durability and efficiency, by delivering goods with the best cost benefit.

CreTEL owes its privileged market position to its ability to develop a standard range of products and tailor-made solutions.

### Hygienic concept

Solid stainless steel construction full welded to prevent dirt and moisture from penetrating inside the cabinet.

Permanent cleaning of the primary roller by a built-in *comb* or *lamel* cleaning system.

### Technical Features

TECHNICAL FEATURES		
MODEL	DESCRIPTION	PROD. SPEED
362 SK	Compact bench tabletop model, equipped with a <b>bolted blade holder and comb cleaning system.</b>	21 m / min
362 SL	Compact bench tabletop model, equipped with a <b>bolted blade holder and Lamel cleaning system.</b>	
362 FK	Compact bench tabletop model, equipped with a <b>blunt skinning shoe and comb cleaning system.</b>	
362 FL	Compact bench tabletop model, equipped with a <b>blunt skinning shoe and Lamel cleaning system</b>	

### Options

OPTIONS		
POS	DESCRIPTION	MODEL
EW001	Electrical wiring 3 x 230V – 50/60 Hz	All models
EW002	Electrical wiring 230V – 50/60 Hz Single phase	
EW002	Electrical wiring 110V – 50/60 Hz Single phase	
TR004	56T toothed roller instead 86T (standard)	
TR005	72T toothed roller instead 86T (standard)	
AC001	Infeed guide plate	
AC003	Pressing roller	
AC005	Extra water snap lock	
JCC036	Stainless steel trolley	
SS002	Deep skin skinning shoe and springs	
BL001	Skinning blades (pack with 5 units)	362 SL

### Applications

**362S** – Equipped with a blade holder skinning shoe for skinning of all kinds of fish fillets such as bream, carp, grouper, mahi-mahi, perch, pike, salmon, trout, tilapia and others. Skinning method: Silver and/or Deep skin

**362F** – The blunt skinning shoe for skinning a wide variety of fish species, either whole or filleted, such as cod, flounder, halibut, mackerel, plaice, ray, skate and others. Skinning method: Silver skin



## Layout

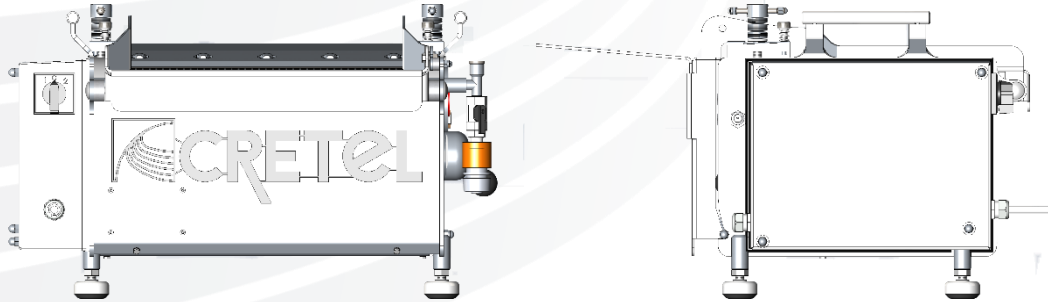

Layout			
Skinning width	Weight	Motor	Dimension (L x W x H)
360 mm	62 kg	0,75 kW	400 x 590 x 340 mm

